

## CNC SYSTEM

220 Bissell Place • San Jacinto, CA 92582  
Phone (951) 487-7680 • Fax (951) 487-7650

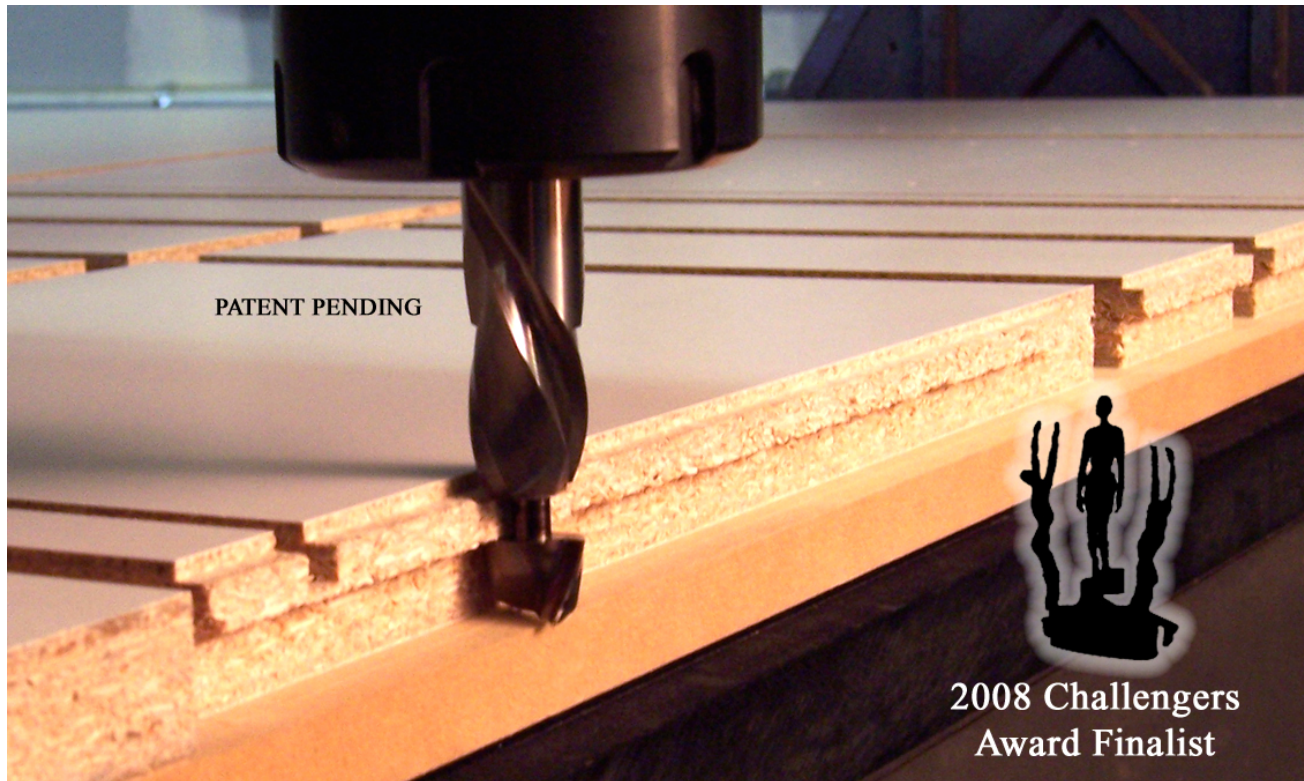

TenonCam is a manufacturing system, consisting of patent pending router bits and software, used to form mortise and tenon joints, In-the-Nest, on a flat table CNC Router. This process is used to produce completely milled cabinet, drawer and toe board parts, without secondary operations or supporting machinery. The concept is to put a 4 x 8 sheet of material on the Router, process it, and then take completely milled, cut to size, parts off the Router. No double handling or secondary machining.

The picture above is of a TenonCam router bit, shown cutting a tenon on a cabinet bottom. The software allows tenons to be cut anywhere In-the-Nest. The TenonCam router bits are available for: 1 inch,  $\frac{3}{4}$  inch,  $\frac{5}{8}$  inch and  $\frac{1}{2}$  inch thick material.

Cabinet backs and drawer bottoms are machined interior face down to the spoil board, so they can be sized for thickness. All other cabinet parts are orientated exterior face down to the spoil board. This ensures that the mortise and tenon joints will be flush, and allows additional machining to be done without having to remove parts from the nest. Please refer to the drawings on sheet four for further clarification.

## **CNC Machining Features:**

- ❑ TenonCam is a Turn-Key system for CNC Nested Based cabinet manufacturing.
- ❑ Engineered for both Frameless and Face Frame cabinet construction methods.
- ❑ TenonCam router bits automatically handle material thickness variations, eliminating the need to continually measure and reenter these variations into the software program.
- ❑ Cabinet body mortise and tenon joints are machined In-the-Nest with Specialized Tooling, which eliminates double handling and the need for secondary operations and machinery.
- ❑ The tenon shoulders hold the cabinet body interior horizontal opening to net size. This ensures that any material thickness variation will go to the outside of the cabinet body horizontally. Therefore, ball bearing type, side mount drawer guides will install without shimming or shaving.
- ❑ The TenonCam System produces a fully milled tenon, orientated exterior face down to the spoil board with a fixed mortise location. Material thickness variations go to the inside of the cabinet body vertically, holding the tops and bottoms flush with the ends.
- ❑ Cabinet backs, drawer and rollout-tray bottoms are sized for thickness and set into dadoes.
- ❑ Construction pilot hole boring for #6 x 1 $\frac{5}{8}$  inch assembly screws (can be switched on/off).
- ❑ Bores only the required number of adjustable shelf holes.
- ❑ System screw and cup boring for concealed hinges and mounting plates (can be switched on/off).
- ❑ System screw guide boring for Blum 230, 430 and Metabox (or equal); Blum Tandem and Tandembox (or equal); also for Accuride 3832 (or equal). Can be switched on/off.
- ❑ Drawer and rollout-tray bodies with mortise and tenon joints are machined In-the-Nest with Specialized Tooling and available for  $\frac{1}{2}$ ,  $\frac{5}{8}$  and  $\frac{3}{4}$  inch thick material.
- ❑ Drawer and rollout-tray backs can be notched In-the-Nest for Blum Tandem guides (or equal).
- ❑ Drawer and rollout-tray sub-fronts can be pilot bored for screws to attach the finished fronts.
- ❑ Detached toe boards with mortise and tenon joints can be made any length and instantly adjusted in height to allow for finished floor thickness. These toe boards can be constructed with 45 and 22 $\frac{1}{2}$  degree miters, which are machined In-the-Nest or skinned with  $\frac{1}{4}$  inch material after installation.
- ❑ Also available - attached (notched) toe boards with mortise and tenon joints. These toe boards are designed to be skinned with  $\frac{1}{4}$  inch material after cabinet installation.
- ❑ Custom programming written specifically to control the TenonCam routing operations. Designed to work in conjunction with the Woodworking Industries' most popular Software Packages.
- ❑ Reduces material handling, part identification, cutting and machining time over conventional methods used to create similar joinery, by up to 80 percent (one man, one day instead of five).
- ❑ Mortise and tenon joints locate the cabinet parts - hole borings locate the hardware and construction screws - the TenonCam System can reduce assembly time by as much as 50 percent.

## **Additional Program Features:**

- ❑ Extensive libraries for Frameless, Face Frame Inset, Face Frame Overlay, Face Frame Lipped and Frame Overlay cabinet styles. There is also, a Closet Library utilizing mortise and tenon construction.
- ❑ All cabinet design standards can still be modified by the user as required.
- ❑ Standard (Non-CNC) dado and butt joint construction methods are available for our Manual Milling customers or as a back up in the event the CNC Machine is down.
- ❑ TenonCam Manual Milling customers can fabricate traditionally or outsource their projects, via e-mail, seamlessly to any company using the TenonCam CNC Machining System.
- ❑ Applied Door, Applied Slab and Integral Finished Ends are all operable from within the same construction method.
- ❑ Corner 90 and 45 cabinets are all operable and stretch correctly.
- ❑ Extensive Door Catalog for manufacturing or buy out applications.
- ❑ Standard (Non-CNC) Dovetail and Doweled drawer and rollout-tray construction methods.
- ❑ Blum Metabox parts can be processed from 5/8 or 3/4 inch material.
- ❑ Enhanced Report Center:
  1. Cutting List of Materials (for each listed below):
  2. Assembly Bill of Materials (for each listed below):
  3. Shipping Lists or Stock Transfers (for each listed below):
    - a. Cabinet Bodies and Face Frames
    - b. Drawer and Rollout-Tray Bodies
    - c. Detached Toe Boards
    - d. Doors, Drawer Fronts and Door Finished Ends
    - e. Panelized (stile & rail) and Slab Finished Backs and Ends.
  4. Material Requirements:
    - a. Lumber (adjusted for waste).
    - b. Sheet Stock (adjusted for waste).
    - c. Hardware.
    - d. Buy Out Doors and Drawer Fronts.
  5. Spot Check Reports: last chance to check for, and correct any errors or inconsistencies in the job - before processing.
- ❑ Improved Molding Catalog - graphic representations do not turn black when printed, as a result of too much detail.
- ❑ Additional graphic layers for Shop Drawings, Face Frame Drawings, Case Body Drawings and the Design Screen.
- ❑ New Catalogs for Corbels, Columns, Pilasters, Split Posts, Feet, Legs, Paneling, Finished Backs and Ends, Appliance Panels, Wood Hoods and Millwork.

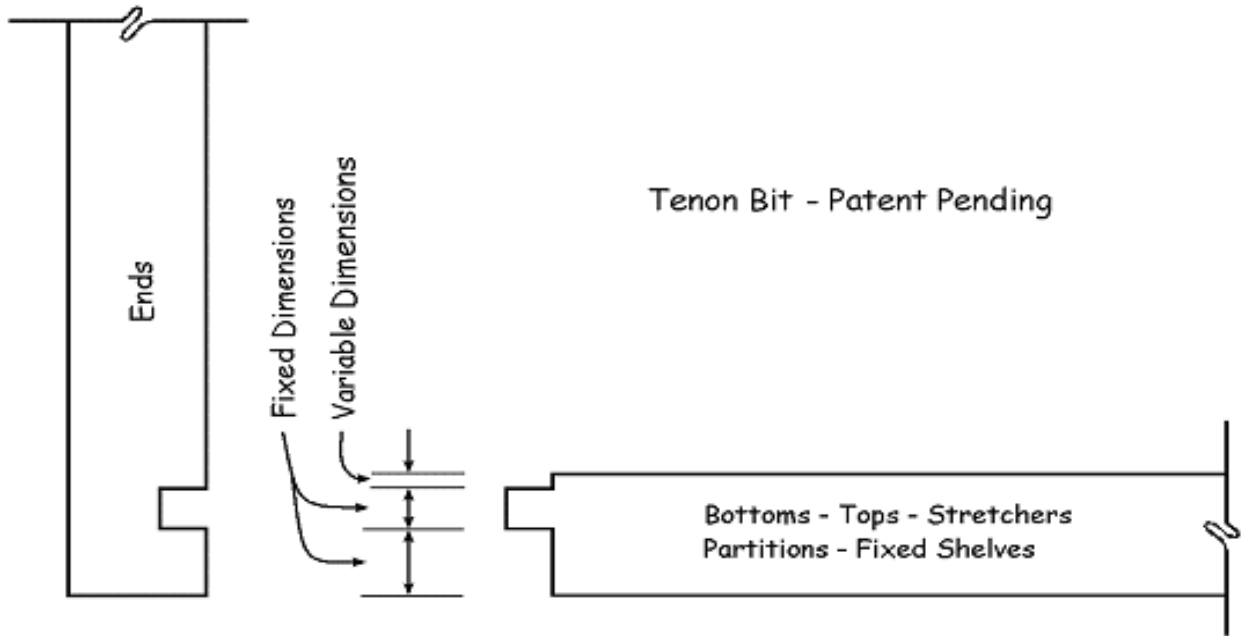

Section At Mortise & Tenon

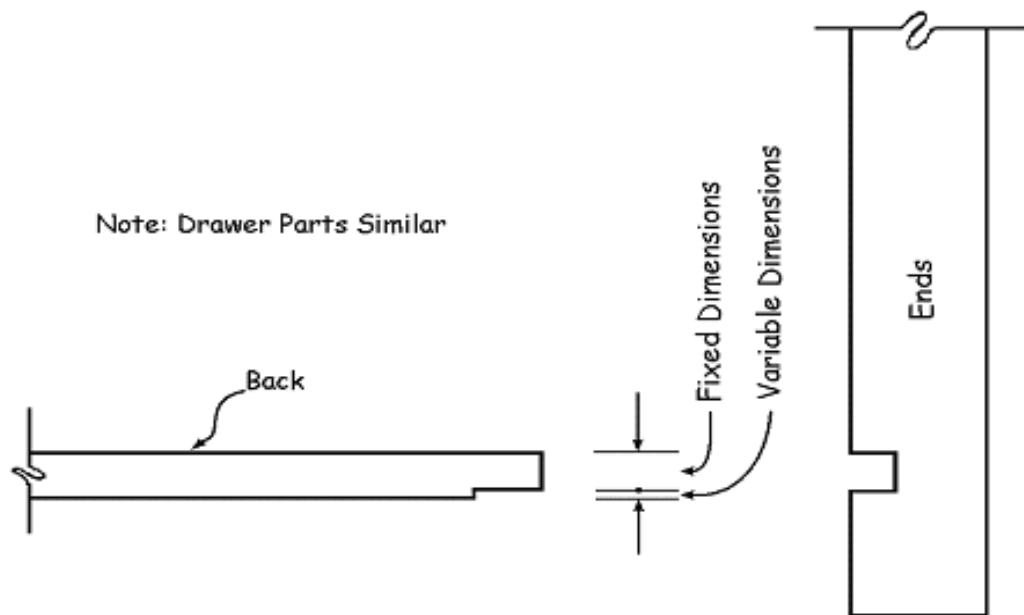

Section At Back Dado

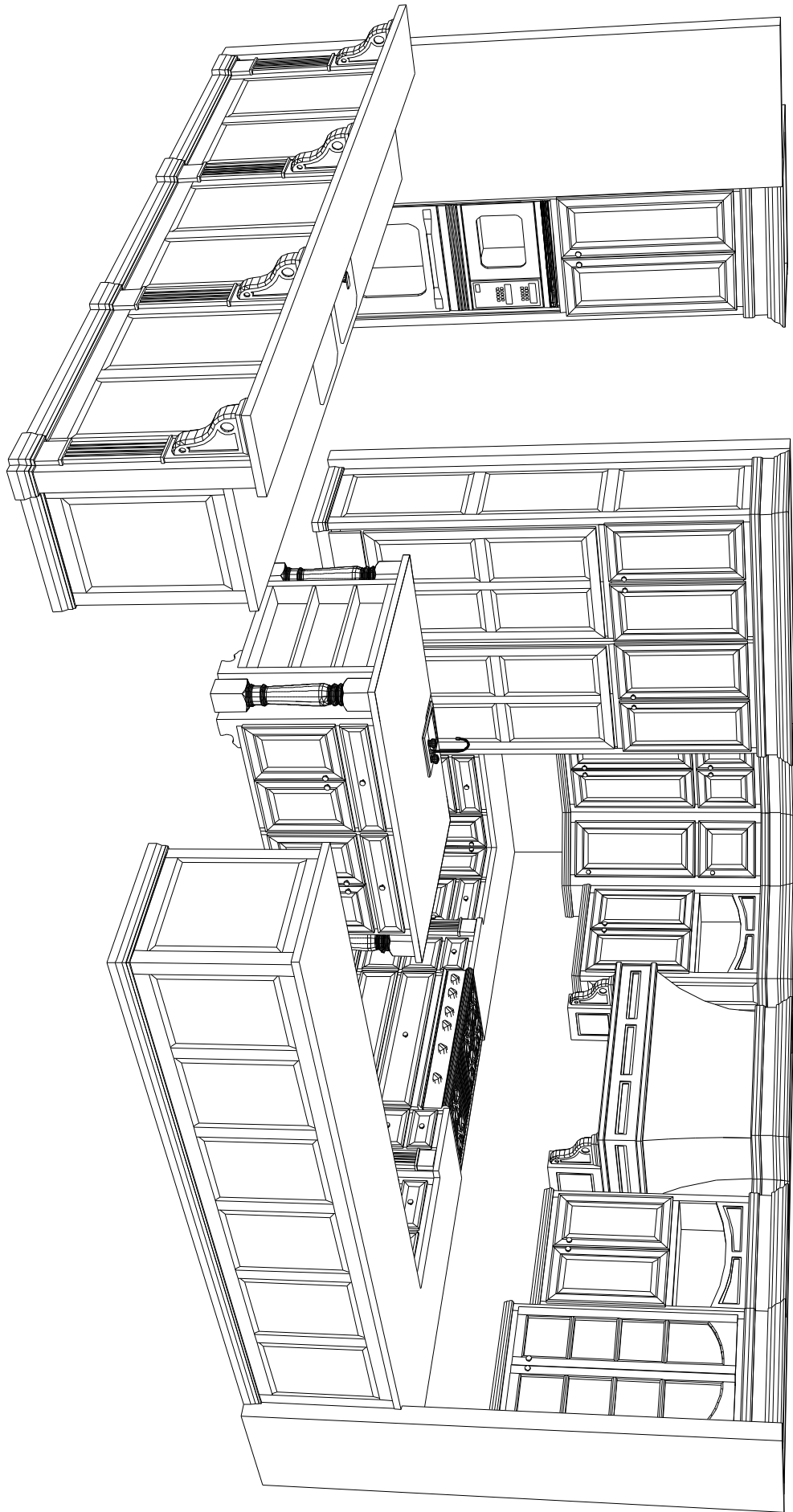

Kitchen Perspective